

## GRADE 2 COMMERCIAL LEVERSET



- Lock chassis are all constructed with cast retractors on bronze roller bearings.
- Has a unique "clutch" mechanism that radically reduces the wear and abuse that typical cylindrical lever sets endure. When locked, the levers of the Survivor disengage from the retractor and other interior mechanisms of the lock. The levers of the Survivor swing freely, without resistance. This reduces the amount of wear on lock components and eliminates "lever droop". The use of a clutch results in longer lasting, lower maintenance, eloquent solution.

### SPECIFICATIONS

- Meet ANSI specification: ANSI-A156.13
- Grade 2 Leverset.
- BHMA Certified
- Lifetime Mechanical Guarantee
- Available in 2-3/8" and 2-3/4" mortise backset
- Made in Amityville, New York, USA

### Door Preparation

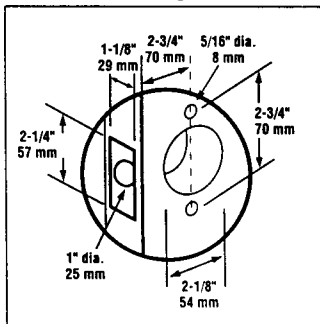

ORDER #	FUNCTION	FINISH	PKG.	UNIT
170N26D	PASSAGE	DULL CHROME	6	EACH
170L26D	PRIVACY	DULL CHROME	6	EACH
170AB26D	KEYED LEVER	DULL CHROME	6	EACH
170F26D	STOREROOM	DULL CHROME	6	EACH
170S26D	CLASSROOM	DULL CHROME	6	EACH
K1704-26D	SPACER RING FOR 1-3/8" DOOR		6	EACH

We offer a huge selection of door locks and door accessories online.

Visit our online catalog today!



**Hardware Hut.com**  
a division of Spokane Hardware Supply, Inc.

## 2000 SERIES E-PLEX LIGHT DUTY ELECTRONIC LOCKSET



- Light-duty commercial cylindrical lockset, solid cast exterior housing & levers, for use in indoor and outdoor applications.
- Requires no wiring to or through the door; Non-handed
- Easy to manage, no software required
- Key override function; Schlage C keyway standard.
- Easily programmed via keypad; 100 Access codes per door; allows four different authority levels of key control including user and service levels.
- Fits 1-5/8" to 2" thick doors standard.
- 2-3/4" backset, 1/2" floating throw latch
- Interior Trim: 3-1/4"W x 8-7/8"H x 2-1/4" Proj.
- Exterior Trim: 3-5/16"W x 8-15/16"H x 2-13/16" Proj.
- Certifications ADA approved; UL 10C Fire Rated.

ORDER #	FUNCTION	FINISH	PKG.	UNIT
E2031XSSL-626-41	COMBO	DULL CHROME	1	EACH

## 5000 SERIES E-PLEX HEAVY DUTY ELECTRONIC LOCKSET



- Extra heavy-duty primary commercial cylindrical lockset, solid cast exterior housing and levers; for use in indoor and outdoor applications.
- Requires no wiring to or through the door; Non-handed.
- Programmed via keypad or with optional Microsoft Excel based software (not included).
- Key override function; Schlage C keyway standard.
- Fits 1-5/8" to 2" thick doors standard.
- 2-3/4in. backset, 1/2in. floating throw latch
- Interior Trim Dimensions: 3-3/16"W x 8-7/8" H x 2-1/8"P
- Exterior Trim Dimensions: 3-3/8"W x 8-7/8"H x 3-13/16"P
- Certifications" ANSI/BHMA A156.25, Grade 1; ADA approved; Three-hour UL/ULC Fire Rated.

ORDER #	FUNCTION	FINISH	PKG.	UNIT
E5031XSWL-626-41	COMBO	DULL CHROME	1	EACH

## 5000 SERIES HEAVY DUTY MECHANICAL LOCKSET

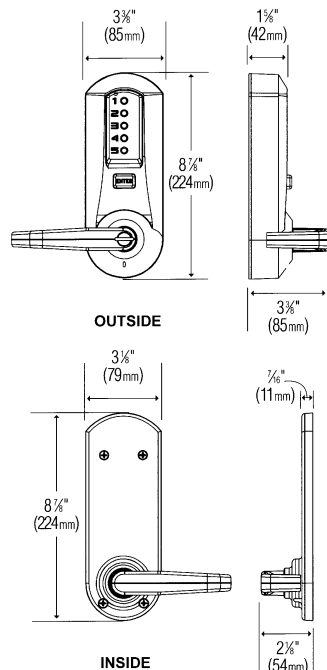

### APPLICATION

- Ideal for controlling access to high-traffic, security sensitive areas on commercial, industrial, educational, governmental, & multi-unit residential settings. Perfect for locations with high turnover rates.

### SPECIFICATIONS

- **Function:** Fully mechanical push-button access control without any wiring, electronics or batteries. Exterior access by combination or key override. Egress is by interior lever & is free at all times.
- **Construction:** Extra heavy-duty cylindrical lock; solid cast housings, solid cast zinc levers, stainless steel cylindrical drive components.
- **Non-handed:** Pre-assembled for left hand, can be field reversed.
- **Numeric Keypad:** Vandal resistant, 5 button metal keys.
- **Door Thickness:** 1-3/8" to 2-1/4".
- **Strike:** ASA & standard strike included.
- **Backset:** 2-3/4" standard, 1/2" floating throw latch.
- Meets A.D.A. accessibility requirements.
- ANSI/BHMA A156.2, Grade 1 certified. 3 hour UL/ULC.

ORDER #	FUNCTION	FINISH	PKG.	UNIT
5021XKWL-26D-41	COMBO	DULL CHROME	1	EACH